

# RADFORD

## DISTORTION MEASURING SET

Series 3

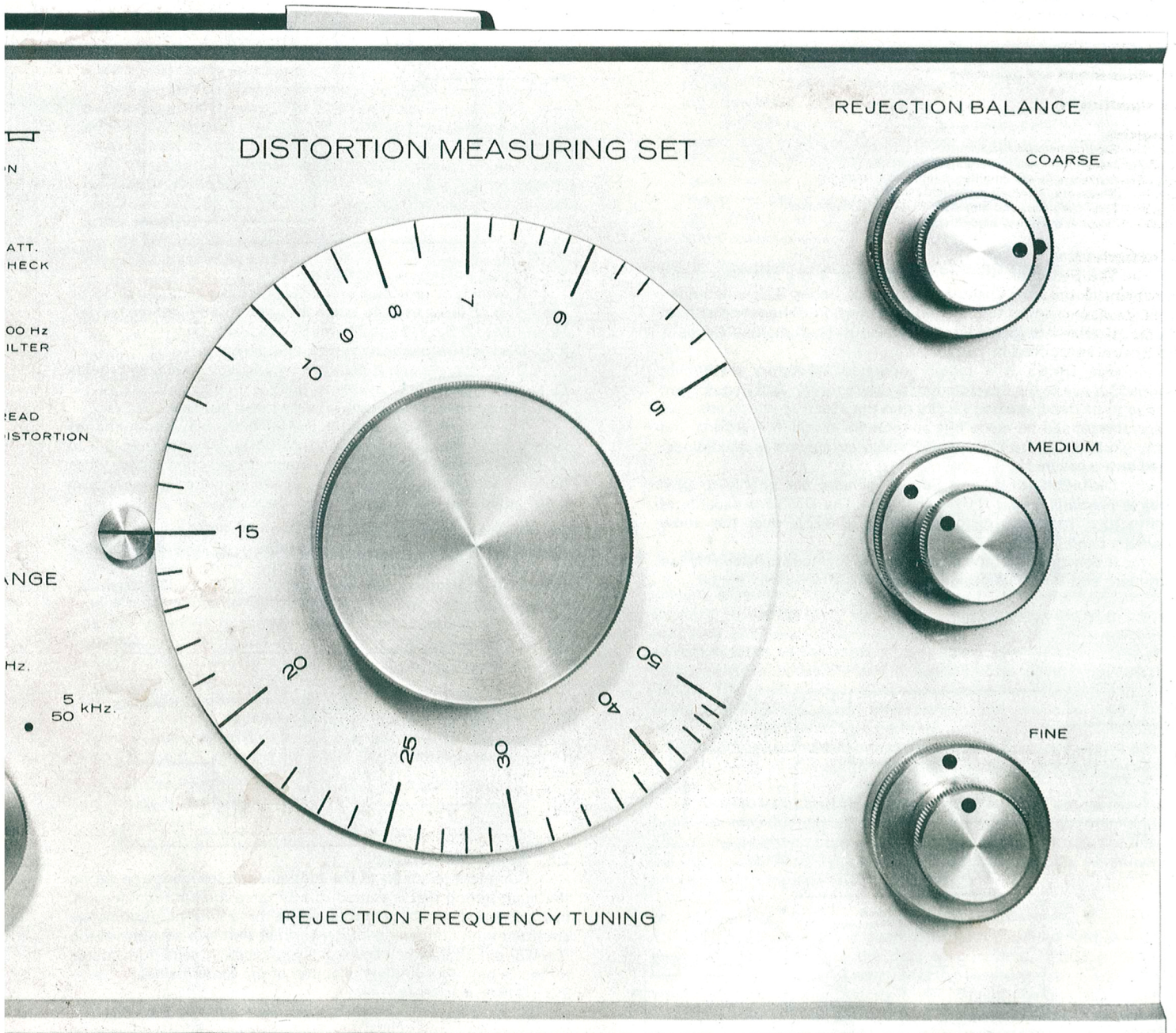



# DISTORTION MEASURING SET

Series 3

## 1. Introduction

### Functions, facilities and controls

- 2.1 Input and output terminations
- 2.2 Input voltage adjustment
- 2.3 Distortion percent range selection
- 2.4 Frequency range adjustment and tuning
- 2.5 Rejection balance
- 2.6 Other controls

## 3. Design details

- 3.1 Design considerations
- 3.2 Input buffer amplifier
- 3.3 Voltage follower amplifier
- 3.4 Measuring amplifier
- 3.5 High pass filter and meter amplifier
- 3.6 'Twin T' rejection circuit
- 3.7 Set f.s.d. attenuator

## 4. Construction

## 5. Maintenance and guarantee

## 6. Specification

### Diagrams

- Fig. 1 Block schematic diagram
- Fig. 2 Input buffer amplifier, simplified circuit
- Fig. 3 Voltage follower amplifier, simplified circuit
- Fig. 4 Measuring amplifier, simplified circuit
- Fig. 5 High pass filter and meter amplifier, simplified circuit
- Fig. 6 'Twin T' rejection, simplified circuit

## 1. Introduction

The Distortion Measuring Set Series 3 is a complementary instrument to the Low Distortion Oscillator Series 3. It is intended for the measurement of total harmonic distortion of frequencies from 5Hz to 50kHz. It supersedes the previous instruments (Series 1 and 2) first introduced in 1960.

The DMS3 is a battery operated laboratory instrument intended for use in the development of high quality audio equipment but due to its direct reading facility and the speed at which effective measurements can be made it is suitable for production testing and in any situation where high quality audio equipment is maintained, tested and measured.

Distortion Measuring Sets in general are unable to give effective readings below 0.01% distortion. The DMS3 is capable of reading total harmonic distortion below 0.002% over the audio frequency band.

A description of the functions and facilities provided by the instrument and the basic design principles are described below.

FIG. 1 BLOCK SCHEMATIC DIAGRAM

FIG. 1a

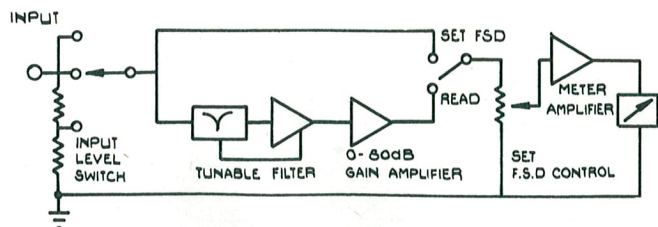
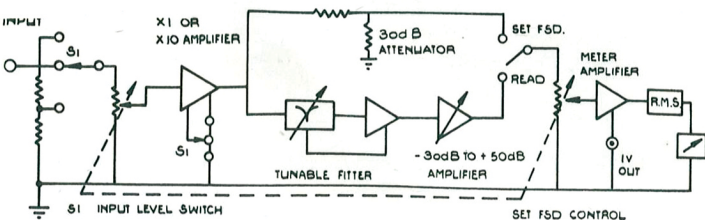

FIG. 1b



## 2. Functions, facilities and controls

### 2.1 Input and output terminations

The input and output terminations of the instrument are terminated by BNC sockets, one side earthy. The purpose of the output socket is to display the residual output after fundamental rejection on an oscilloscope. This enables an assessment to be made of the harmonic distortion structure, the character and energy content of noise, crossover spikes, and spurious responses.

FIG. 2 INPUT BUFFER AMPLIFIER, SIMPLIFIED CIRCUIT

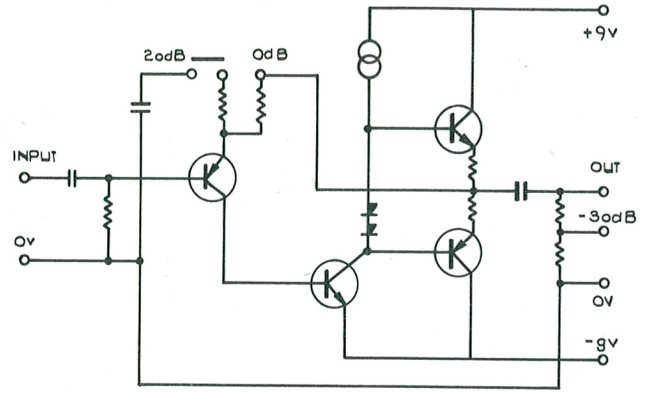

### 2.2 Input voltage adjustment

A switch is provided which enables the instrument to be used over an input voltage range of 50mV to 50V in three ranges, i.e. 50mV to 0.5V, 0.5V to 5V, and 5V to 50V.

### 2.3 Distortion percent range selection

Distortion percent is selected by a 9-way switch to provide f.s.d. meter readings of 0.01% to 100%.

### 2.4 Frequency range adjustment and tuning

The frequency range of the DMS3 is divided into four bands with a small overlap as follows: 5 to 50Hz, 50 to 500Hz, 0.5 to 5kHz and 5kHz to 50kHz. The frequency of rejection within these bands is selected by a large 3-gang potentiometer operated from a 4 1/2" calibrated dial with a 2" diameter knob.

FIG. 3 VOLTAGE FOLLOWER AMPLIFIER, SIMPLIFIED CIRCUIT

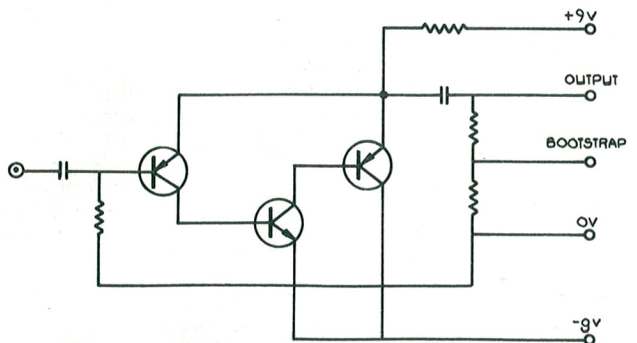

### 2.5 Rejection balance

Complete rejection of the fundamental frequency as set on the main tuning dial is carried out by three dual potentiometers, marked coarse, medium and fine. The three twin potentiometers are fitted with concentric knobs in order that two sections of the 'Twin T' circuit may be successively adjusted in pairs from coarse to fine to provide complete rejection of the fundamental.

### 2.6 Other controls

A push-button switch having four buttons provides the following functions: ON/OFF, Battery check, 500Hz high pass filter, Set f.s.d./Read distortion.



FIG. 4 MEASURING AMPLIFIER, SIMPLIFIED CIRCUIT

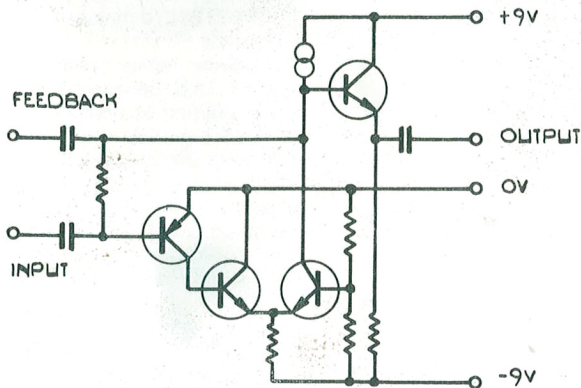

3. Design Details

3.1 Design considerations

The DMS3 is fundamentally a notch rejection filter. Feedback is applied around the filter in order to sharpen the rejection and not significantly attenuate the second harmonic. The output of the filter is measured by r.m.s. voltmeter and compared with the original signal input level.

A schematic diagram showing the principle of operation of a Distortion Measuring Set is shown in Fig. 1a. This is the arrangement used in the DMS1 and DMS2. The disadvantage of this arrangement is that the impedance of the rejection circuit varies with the setting of the tuning potentiometer. If the source resistance of the unit under test is high then it can be seen that distortion may be introduced by loading the input circuit under some conditions. The use of a buffer amplifier between the signal source and the rejection filter overcomes this problem and some distortion measuring sets have used this principle for some years. In the past the use of a buffer amplifier has resulted in the introduction of distortion of the original signal as well as an increased noise level. For this reason the DMS1 and DMS2 did not use a buffer amplifier and was thus able to read lower distortion levels by almost a factor of 10 than other Distortion Measuring Sets. Bearing in mind the advantages of an input buffer amplifier and recent developments in semi-conductors and techniques, development was initiated to produce a suitable buffer amplifier with virtually zero distortion over the audio frequency band with a noise level at almost the theoretical minimum. Successful development has enabled a circuit improvement as shown by the block diagram, Fig. 1b.

3.2 Input Buffer amplifier

The amplifier features two complementary voltage gain stages followed by a unity gain buffer. The symmetrical output stage cancels even harmonic distortion, whilst keeping the current drain low. Because of the low output power level the stage does not enter the Class B region. The distortion produced by the amplifier is virtually unmeasurable and does not affect the measured distortion of an input signal except at very high frequencies outside of the audio band. A simplified circuit is shown in Fig. 2.

3.3 Voltage follower amplifier

The voltage follower amplifier buffers the output of the 'Twin T' network. It is essential that distortion is not introduced into the 'Twin T' network by a non linear output impedance. The

FIG. 5 HIGH PASS FILTER AND METER AMPLIFIER, SIMPLIFIED CIRCUIT

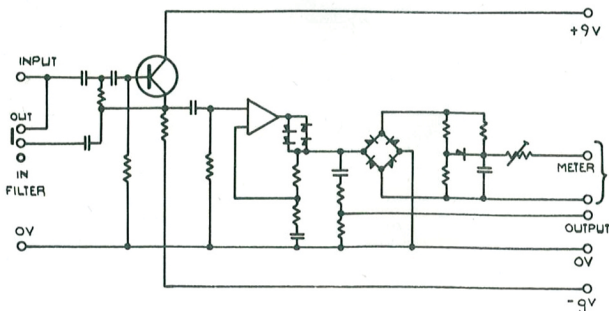

output impedance has been designed to be very low and linear. A simplified circuit of the voltage follower amplifier is shown in Fig. 3.

3.4 Measuring amplifier

The nine distortion ranges from 100% to 0.01% f.s.d. are obtained by switching the gain of the measuring amplifier from 30dB attenuation to 50dB gain. The design requirements for stability, and to provide equal roll off of 1dB at 250kHz at all positions of the gain switch are quite complex. A simplified diagram of the amplifier is shown in Fig. 4, and its function in the complete instrument can be seen from the block schematic diagram, Fig. 1b.

3.5 High pass filter and meter amplifier

In order to reduce errors in the r.m.s. rectifier a high working level is obtained with an operational amplifier. The meter has a linear scale and reads r.m.s. values up to a crest factor of 3. A second order high pass filter with a corner frequency of 500Hz is used at the input of the measuring amplifier. The filter may be switched into circuit for measurements at 1kHz and above, eliminating hum and low frequency noise in the equipment under test. A simplified circuit of the filter and meter amplifier is shown in Fig. 5.

3.6 'Twin T' rejection circuit

The DMS3 is tuned by a large 3-gang potentiometer and the capacitors are switched in four decade ranges. A simplified circuit of the 'Twin T' network is shown in Fig. 6.

3.7 Set f.s.d. attenuator

As will be seen from the schematic diagram, Fig. 1, the input signal is adjusted to full scale deflection on the meter by a twin-gang potentiometer P.1a and P.1b after the adjustment of input level by the switch S.1 when the rejection circuit and measuring amplifier are out of circuit. The distortion products, after rejection are measured in precise value by gain adjustment in the measuring amplifier.

FIG. 6 'TWIN T' REJECTION, SIMPLIFIED CIRCUIT

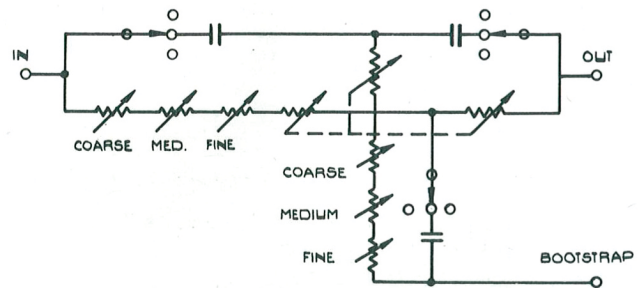

4. Construction

The Distortion Measuring Set is constructed on an open chassis assembly. The chassis front and rear panels are secured together by spacer bars. The front fascia comprises a screen printed anodised aluminium trim panel, affixed to an anodised aluminium extrusion fitted to the chassis front panel. The chassis assembly is enclosed by a baseplate and a wrap around cover with carrying handle. The chassis assembly is constructed from 18 swg. mild steel sheet and finished bright zinc plated. The cover is made from aluminium coated with texture finish matt black plastic. The knobs are lathe turned from solid aluminium bar and finished clear anodised. The frequency dial is aluminium sheet, deep etched, anodised, and screen printed.

The electronic circuits are constructed on glass epoxy printed wiring boards, screen printed with component identification and connecting wire numbers and colour. Connections to the boards are made with 'Amp' type connectors for easy service. All components are of the highest quality obtainable.

5. Guarantee

The instrument is guaranteed in the United Kingdom for a period of one year from the date of purchase. It covers the free replacement or repair of any defective component or part of the equipment during this period. It also covers the cost of labour in executing the repair or replacement if the instrument is returned to the factory service department, carriage paid, within the guarantee period.



**Specification**

Frequency range: 5Hz to 50kHz (four bands)  
 Distortion percent range: 0.01% f.s.d. to 100% f.s.d.  
 Accuracy of distortion percent attenuator: 1%  
 Input voltage range: 50mV to 50V. Three ranges 50mV-0.5V, 0.5V-5V, and 5V-50V. (50mV-0.5V range not operative on 0.01% and 0.03% f.s.d. ranges).  
 2nd harmonic attenuation: 0.5dB

Frequency response bandwidth: 250kHz (-1dB)  
 High pass filter: 500Hz (12dB/octave)  
 Input resistance: 47k ohms  
 Meter: 4" mirror scale engraved 0-1, 0.3-16, f.s.d. dB and battery check. r.m.s. reading to crest factor 3.  
 Calibrations: 2 x PP9 batteries (included).  
 Power source: 17" wide x 7" high x 9" deep (43 x 17.8 x 23 cm)  
 Size: 16½ lb (7.5 kg).  
 Weight: 24 lb (11.0 kg) packed for transport.

RADFORD INSTRUMENTS LTD. BRISTOL BS3 2HZ ENGLAND

